

Synchronous motor 58S-12 同步电机 58S-12

Technical Data 技术数据

Item	Unit	Frequency	
		50 Hz	60 Hz
Rated speed 额定转速	rpm	250	300
Synchronous torque 同步扭矩	Ncm	12.5	10.2
Delivery of power 输出功率	W	3.27	3.20
Power consumption 功耗	W	8	9
Rated current (230 V) 额定电流	mA	32	29
Operating capacitor 电容	F	0.22	0.22
Max. externally permitted mass moment of inertia 允许的最大外部惯量	gcm ²	250	250
Self-holding torque, typical 自锁扭矩	Ncm	1.2	1.2
Excess winding temperature 绕组温升	K	46	50
Permitted radial force 允许径向力 F_r	N	9	9
Permitted axial force 允许轴向力 F_{as}	N	2.5	2.5
Weight 重量	kg	0.38	
Protection grade 防护等级		IP 41	
Insulation class 绝缘等级		E	
Dielectric strength 介电强度		according to IEC 60034-1	

Ordering code 订货号		100175		100177		100178	
Rated voltage 额定电压	V	230		48		24	
Frequency 频率	Hz	50	60	50	60	50	60
Operating capacitor 电容	F	0.22	0.22	7.1	7.1	22	22
Rated current 额定电流	mA	32	29	180	193	305	316

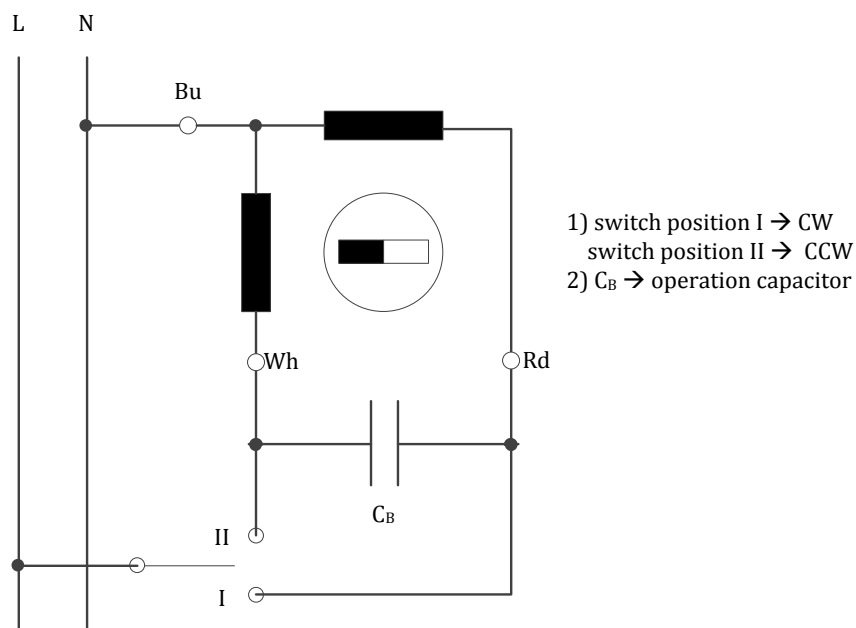

Wiring 58s-12 接线图

Synchronous motor 58S-12 同步电机 58S-12

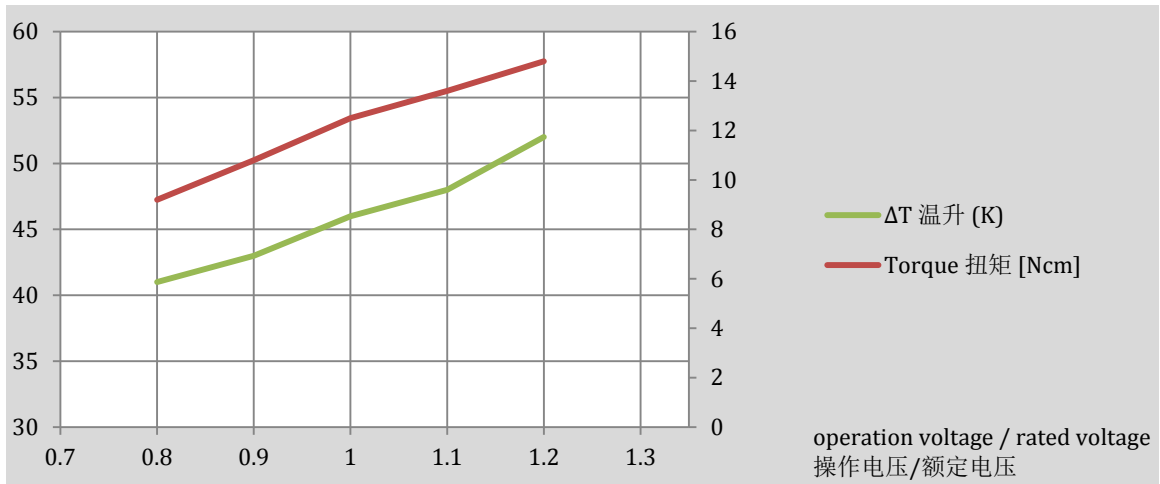

Characteristic curve 58s-12 at 50 Hz 特性曲线@50 Hz

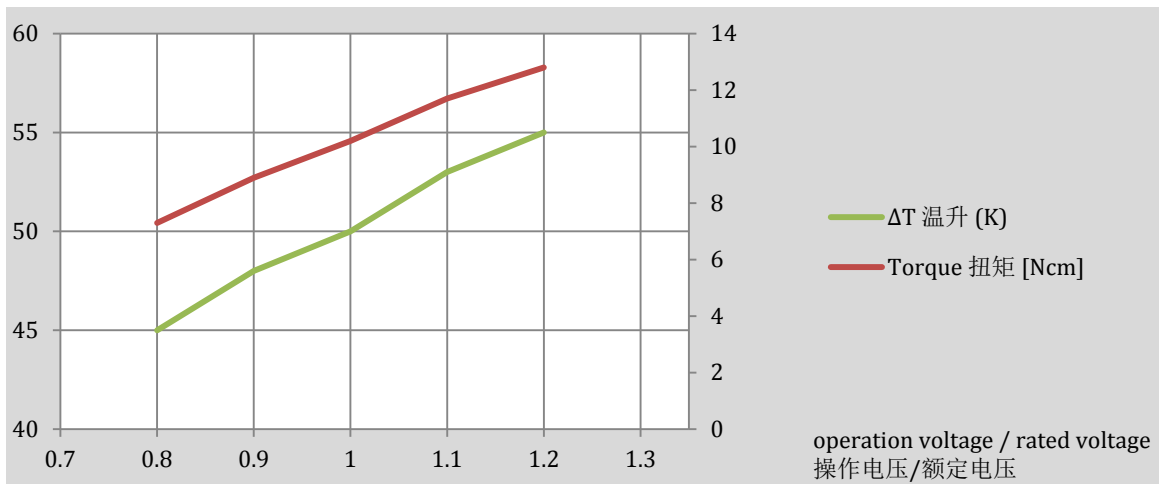

Characteristic curve 58s-12 at 60 Hz 特性曲线@60 Hz

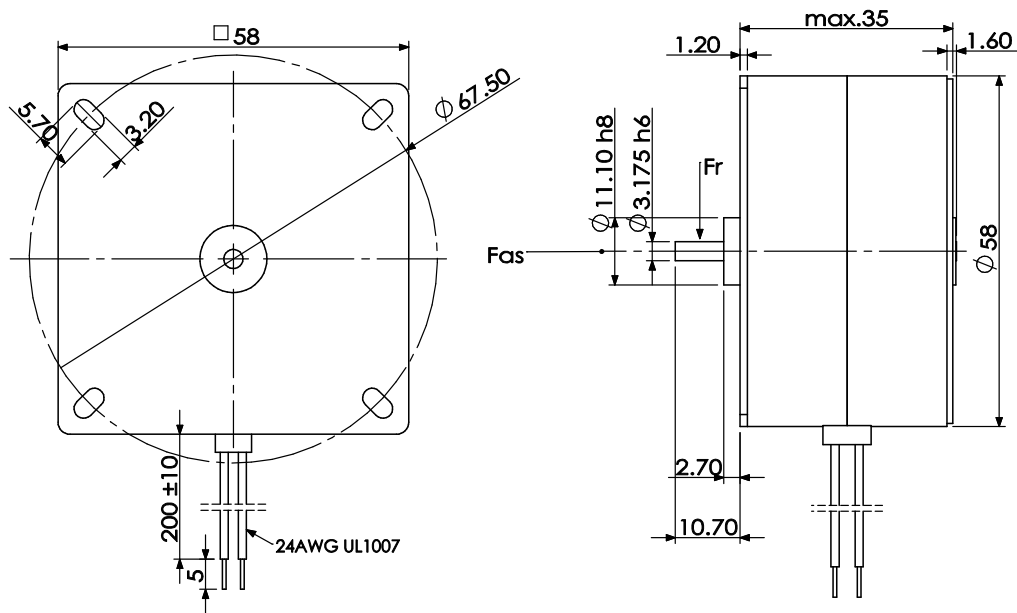

Demension 尺寸图